

Locker TV Media Cart

Assembly Instructions

STOP!

Please read the following important information!

For questions on assembly or parts, **DO NOT RETURN** product to the store. Contact the experts at *Elite Products* by calling **TOLL FREE.**

1-800-656-6730

Monday-Friday 8am-4pm (Pacific Standard Time)

***This product contains two boxes.
Box one and box two is needed to complete unit.***



(Please keep this for future reference)

Important: When assembling, place on a smooth clean surface to prevent scratching.

Note: DO NOT fully tighten bolts until all bolts are in place.

Step one :

Attach all panels (A&B), using 12 qty silver flat head allen bolts (1/4 " x 5/8 ", #1 on hardware list) indicated on diagram below.

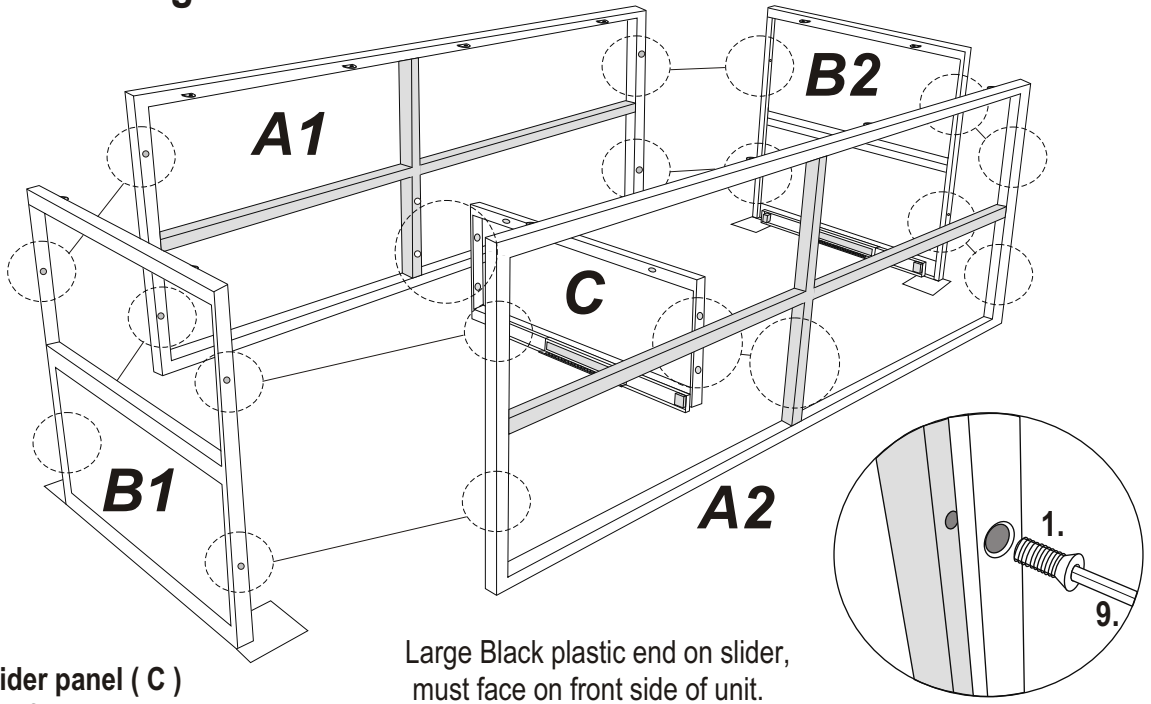
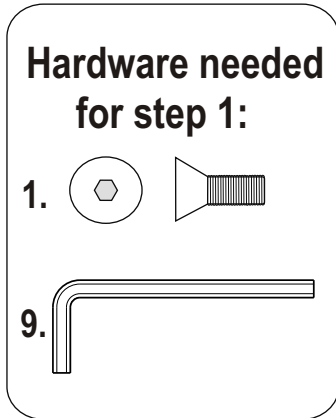

IMPORTANT!

Panels A & B and small divider panel (C) must be facing the correct way before assembly.

Step two : A Phillips screwdriver is required.

Attach shelves using 20 qty silver pan head phillips bolts (3/16 " x 3/8 ", # 2 on hardware list) shown on diagram below.

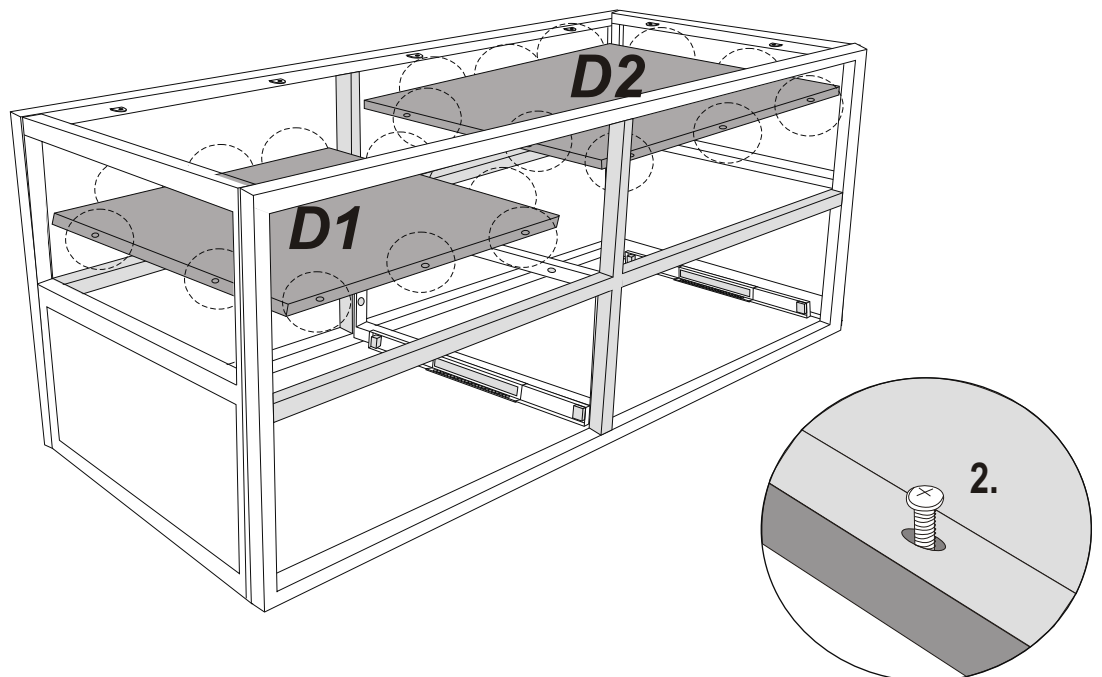

Reminder! *DO NOT* fully tighten bolts until all bolts are in place on each step/.

Step three :

Attach top base (E) with 12 qty silver pan head phillips screws(1/8 " x 5/8 ", # 3 on hardware list) shown on diagram below.

Hardware needed for step 3:

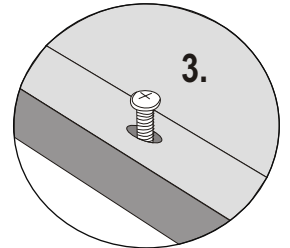
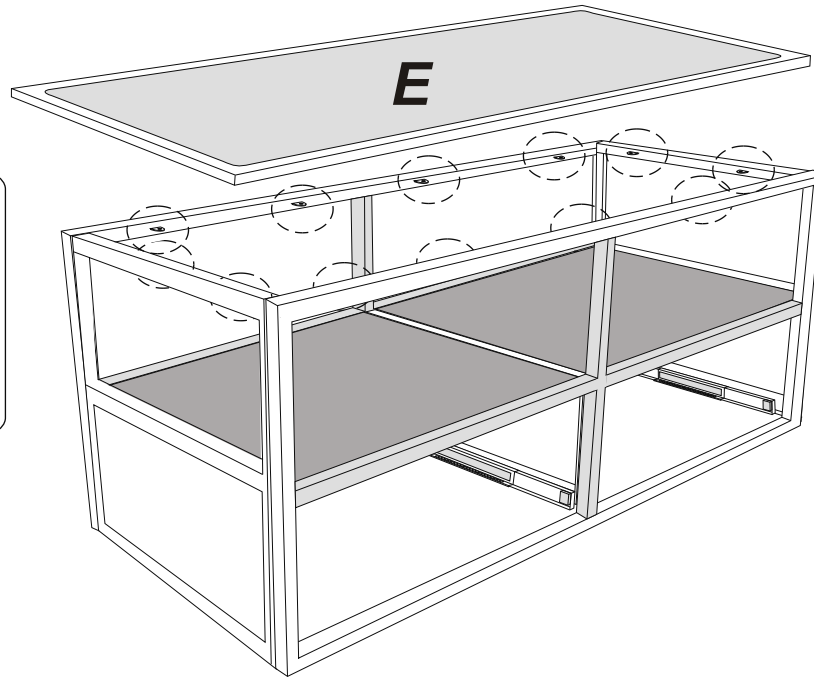

Step four : *A Phillips screwdriver is required.*

Attach all 4 Caster wheels (#10) using 16 qty silver flat head allen bolts (1/4 " x 5/8 ", # 4 on hardware list) demonstrate on diagram below. Now position drawers in media cart.

Hardware needed for step 4:

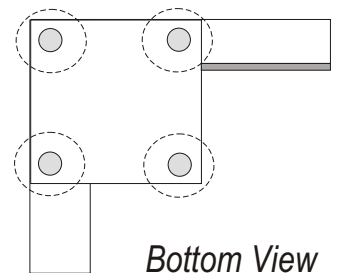
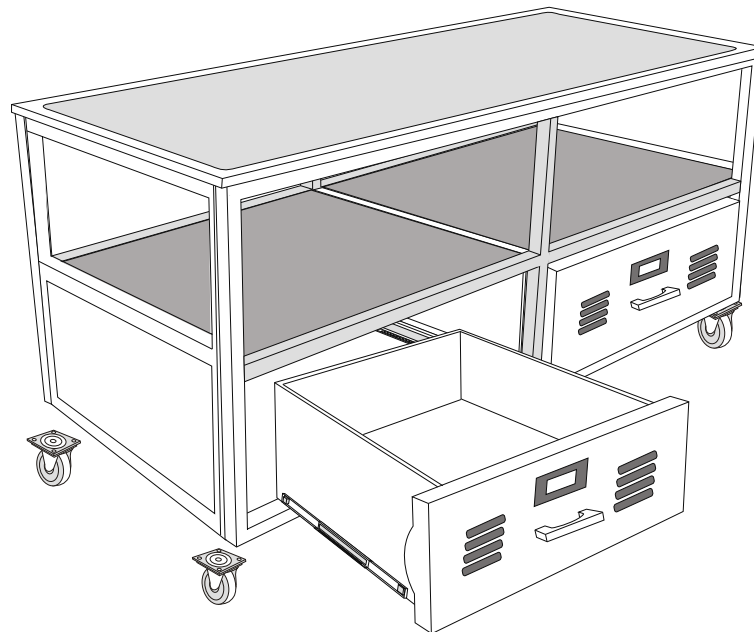



















Place bolts indicating on diagram.

Locker TV Media Cart Assembly Instructions Sheet

For questions on assembly or parts, **DO NOT RETURN** this product to the store. Contact experts at Elite Products by calling **TOLL FREE 1800-656-6730**.

Please check parts list for correct hardware count. Locker Furniture may come in multiple package's hardware packed inside. The quantities listed are the minimum required, **you may receive extra hardware.** ***Important: When assembling this product, do it on a soft smooth surface, so you don't scratch it.***

Parts List Components and Hardware

- | | | | | | | | |
|----|---|---|--|-----|---|---|--------------------------|
| 1. |  |  | 1/4" x 5/8" Silver Flat Allen head bolts (12 pieces) | 7. |  |  | Cam locks (8 pieces) |
| 2. |  |  | 3/16" x 3/8" Silver Pan head Phillips bolts (28 pieces) | 8. |  |  | Cam lock pins (8 pieces) |
| 3. |  |  | 5/32" x 3/8" Silver Pan head Phillips screws (12 pieces) | 9. |  | | Allen Key (1 piece) |
| 4. |  |  | 1/4" x 5/8" Silver Pan head Phillips bolts (16 pieces) | 10. |  | | Caster wheels (4 pieces) |
| 5. |  |  | 5/32" x 3/8" Silver Pan head Phillips screws (20 pieces) | 11. |  | | Washer (12 pieces) |
| 6. |  |  | 5/32" x 1/4" Silver Pan head Phillips bolts (4 pieces) | | | | |

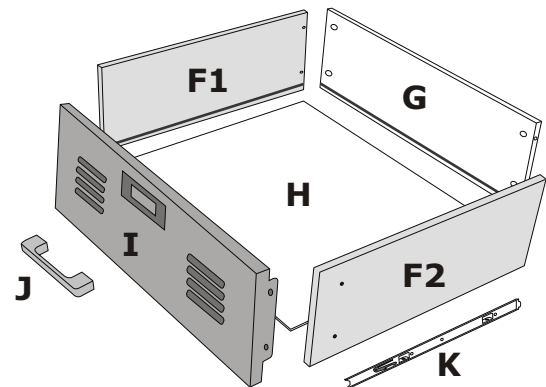
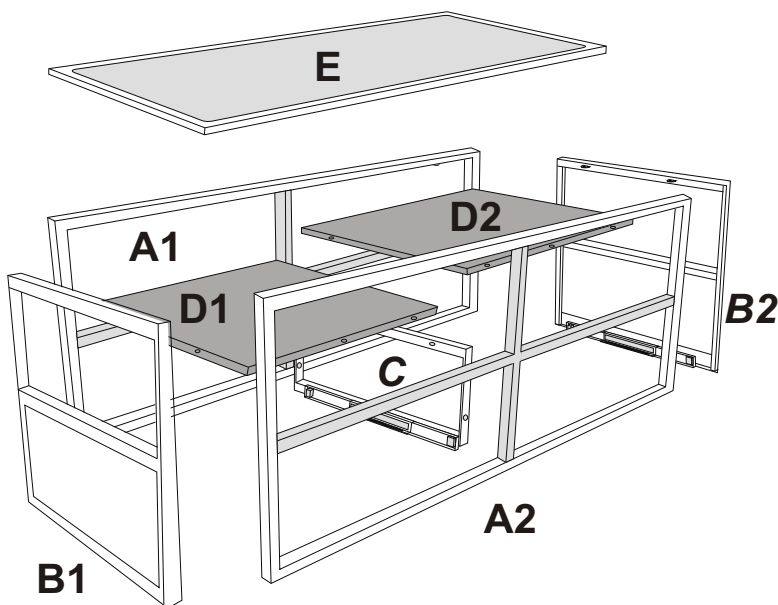

- A. Front and Back panels (1pcs each)
- B. Side Panels (2pcs)
- C. Small Center Divider panel (1pcs)
- D. Shelves (2pcs)
- E. Top base (1pcs)

- F. Drawer side panel (2pcs)
- G. Drawer back panel (2pcs)
- H. Drawer bottom base (2pcs)
- I. Drawer Front Locker panel (2pcs)
- with optional color panels each (3pcs Extra)*
- J. Drawer handle (2pcs)
- K. Sliders (4pcs)